

## Millimeter wave radar

---

# 24GHz velocity radar

## HLK- LD2415H datasheet

— Focus on the design and development of millimeter wave radar products

This manual will describe the design principles, technical parameters, installation specifications and other matters of the HLK-LD2415H radar module to guide you to understand and use this radar product in detail. Our company reserves the right to make regular changes to the contents of this manual without prior notice. The changed content will be added to the new version of the product manual. Please contact our company in time to obtain the latest information.

### Version

Version	Date	Page	Involving chapters
1.0	2021.10.22	7	All
2.0	2023.10.22	7	All

## 1. Overview

HLK-LD2415H speed radar is a millimeter wave radar module integrating microstrip antenna, radio frequency circuit and signal processing circuit, which directly outputs the speed information of the target. It can be used for long-distance car speed measurement up to 180 meters or more. It adopts integrated radio frequency chip, has extremely high frequency stability and speed measurement accuracy of 1KM/h.

It is widely used in speed reminders on various roads such as highways, urban trunk lines, city and county highways, urban and rural trunk roads, as well as road curve and intersection warnings.

## 2. Feature description

- ◆ K-band radio frequency integrated circuit design;
- ◆ Frequency range: 24.125GHz (customizable frequency)
- ◆ Modulation method: CW detects moving vehicles, detection distance  $\geq 180$  meters
- ◆ Supports RS485 interface and TTL serial port (baud rate 9600bps)
- ◆ Speed measurement range: 1KM/H ~240KM/H
- ◆ The speed measurement error is less than  $\pm 1$ KM/H (when the angle between the movement direction and the radar beam azimuth is zero degrees)
- ◆ Voltage: 9~24V, current  $\leq 50$ mA@12V
- ◆ Output power (EIRP): 20dBm; actual power consumption  $\leq 1.2$ W
- ◆ Antenna angle: horizontal  $40^\circ$ , pitch  $16^\circ$  (3dB beam width, actual detection angle is greater than 4 lanes)
- ◆ Sensor size: 69\*53\*5mm

## 3. Product effect

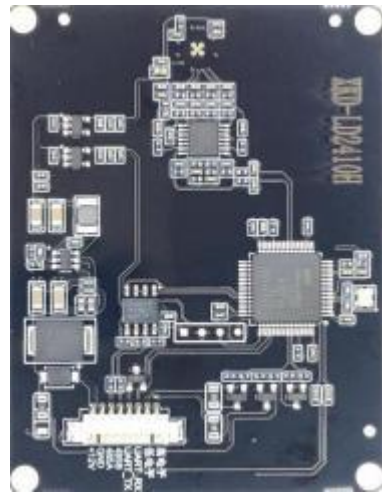
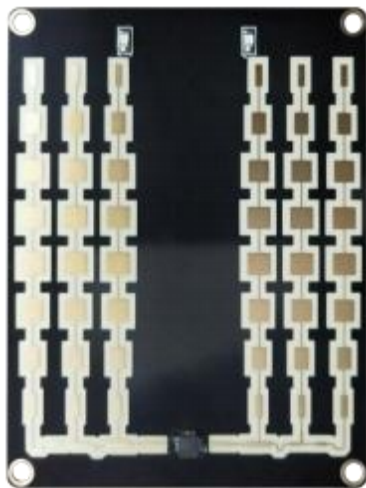

Product PCBA renderings

## 4. Main parameters

Parameters	Symbol	Minimum value	Typical value	Maximum value	Unit	Explanation
Transmitter						
Transmission frequency	$f$	24.075	24.125	24.175	GHz	Customizable
Output Power ( EIRP)	Pout		18	20	dBm	Customizable
Antenna angle						
Transmitting antenna gain			16		dBi	
Receive antenna gain			18.4		dBi	
Transmitting antenna radiation angle			$\pm 20$		deg	Level
Receive antenna radiation angle			$\pm 8$		deg	Vertical
			$\pm 20$		deg	Level
			$\pm 8$		deg	Vertical
Power supply						
Operating voltage	VCC	9	12	24	V	
Operating current	ICC		50		mA	
Interface parameters						
Pulse interface	VCC	9	12	24	V	
Environment						
Operating temperature	TOP	- 20		+ 85	°C	
Storage temperature	TOP	- 40		+ 125	°C	
Dimensions	Length 69 x Width 53 x Height 5				mm	

Module main technical parameters table

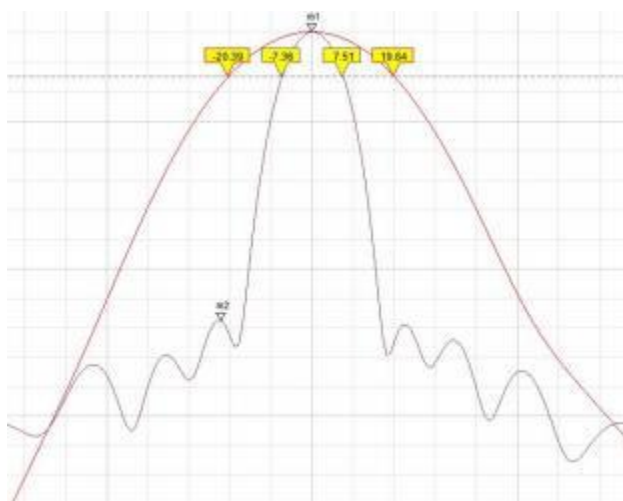

Antenna pattern

## 5. Interface description

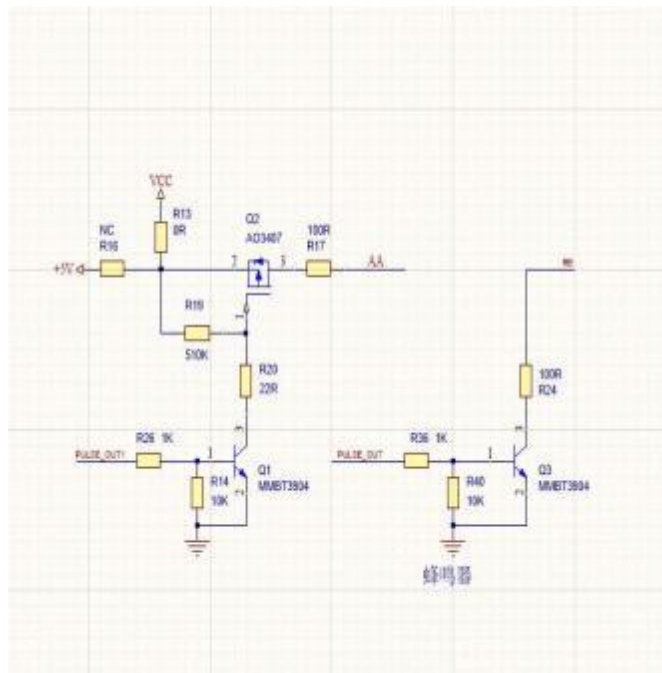
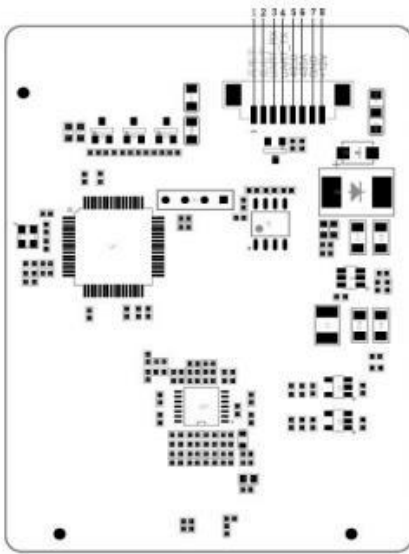

Interface diagram (shown from the back of the module)

When the early warning signal function is required, the radar can directly output a high-level active signal (pin 1) or a low-level active signal (pin 2).

Serial number	Pin name	J4 description
1	Pin 1	PULSE (The radar board is a high-level active output signal version: a high-level active output pin)
2	Pin 2	AA (The radar board is the active low output signal version: active low output pin)
3	UART_RX	Receive
4	UART_TX	Send
5	B	485 serial port data B
6	A	485 serial port data A
7	GND	Power ground
8	VCC	9~24V power

Interface function description table

## 6. Communication protocol description

RS485 and UART serial port (3.3V TTL level signal) speed data output format (baud rate 9600bps, 9 bytes per frame data packet).

### 6.1 : Coming target

V (ascii) + (ascii) hundreds (ascii) tens (ascii) units (ascii) decimal point (ascii) decimal place (ascii) 0x0D0x0A

```
V+001.8
V+001.8
V+001.8
```

## 6.2 : Going target

V (ascii) - (ascii) hundreds (ascii) tens (ascii) units (ascii) decimal point (ascii) decimal place (ascii) 0x0D0x0A

V-001.9  
V-001.9  
V-001.9

## 6.3 : Radar parameter setting command

0x43+0x46+0x01 function code		
Command format : 0x43+0x46+0x01+lower limit value of speed range+angle compensation+sensitivity+0x0d+0x0a		
Set speed range lower limit value, angle compensation, sensitivity	Command	43 46 01 01 00 05 0d 0a
	Explanation	<p>Note 1 : 0x01 is the lower limit value of the speed range 1KM/H (Factory default is 0X01) , If 0x01 is set, speeds less than 1km/h will not be detected and output. ;</p> <p>Note 2 : 0x00 is the angle compensation of the angle between the center of the radar beam axis and the movement of the moved target (car) (factory default is 0x00). If 0x0a is set, the angle compensation angle is 10 degrees. ;</p> <p>Note 3 : 0x05 is the configurable range of radar sensitivity setting 0x01~0x0f (factory default is 0x05); the smaller the sensitivity value, the higher the sensitivity, so the longer the detection distance (poor anti-interference); the larger the sensitivity value, the lower the sensitivity, that is, so the closer the detection distance (strong anti-interference); if there is interference caused by a strong radio transmitting antenna near the radar sensor or the ripple coefficient of the radar sensor power supply is large, the sensitivity value needs to be appropriately increased to improve the anti-interference performance. Please make your own choice based on application conditions.</p>
0x43+0x46+0x02 function code		
Command format : 0x43+0x46+0x02+coming/going target detection output+measurable speed output times per second+Kilometers per hour/miles per hour switch+0x0d+0x0a		
Set the coming/going target detection output, measurable speed output times per second, kilometers per hour/miles per hour switching	Command	43 46 02 00 01 00 0d 0a
	Explanation	<p>Note 1 : 0x00 0x00 detects and outputs for both coming and going targets; 0X01 only detects and outputs coming targets; 0X02 only detects and outputs going targets;</p> <p>Note 2 : The larger the value of 0x01, the lower the number of times the radar sensor can measure speed per second; 0X00 is about 22 frames per second; each increment of 1 to the setting value increases the time by 1 times, if 0x01 is set, the output is 11 frames per second (the factory default is 0X01, every (about 11 frames per second));</p> <p>Note 3 : The speed unit of 0x00 is kilometers per hour; the speed unit of 0x01 is miles per hour; the speed unit of 0x02 is meters per second;</p>
0x43+0x46+0x03 function code		
Command format: 0x43+0x46+0x03+0x00+0x00+0x00+0x0d+0x0a		
	Command	43 46 03 00 00 00 0d 0a

Set the anti-interference coefficient of vibration interference in the range 0x00-0x70 (factory default is 0X00)	Explanation	Note 1 : <b>0x00</b> vibration interference generally refers to targets that move "back and forth" with small swings (such as speaker pronunciation, vibration of the mounting bracket of the radar sensor itself, or interference from electric fans, etc.); the larger the XU value range, the greater the anti-vibration swing, but It is easy to miss the target of short-stroke movement. Please adjust and make your own choices according to the application scenario.
0x43+0x46+0x04 function code (Only when using the photocoupler function)		
Command format : 0x43+0x46+0x04+relay closing time (seconds)+the minimum speed value for the relay to close(km/h)+0x00+0x0d+0x0a		
Set parameters for relay output	Command	43 46 04 <b>00</b> <b>00</b> 0d 0a
	Explanation	Note 1 : <b>0x00</b> setting range 0x00~0xff; Default value 0; When the speed value exceeds 00, the photocoupler pull-in time (seconds); Note 2 : <b>0x00</b> setting range 0x00~0xff; default value 0; minimum speed value (km/h) for photocoupler pickup.
0x43+0x46+0x05+0x01 function code		
Command format : 0x43+0x46+0x05+0x01+0x00+0x00+0x00+0x00+0x00+0x00+0x00		
Switch to custom protocol mode 01	Command	43 46 05 01 00 00 00 00 00 00
	Explanation	Radar response: Switch to CSR Mode... Done.
Switch to standard protocol mode 02	Command	FA 31 30 30 FB [Wait for Radar's reply before sending the next one] FA 55 AA FF FB
	Explanation	Radar response: Switch to CSR Mode... Done.
0x43+0x46+0x07 function code		
Command format : 0x43+0x46+0x07+0x00+0x00+0x00+0x00+0x00+0x00+0x00+0x00+0x00		
Read the set parameters	Command	43 46 07 00 00 00 00 00 00 00 00 00 (该命令仅在标准协议模式下适用)
	Explanation	Radar response : <b>No. : 20210726 v3.0</b> <b>X1:01 X2:00 X3:05 X4:00 X5:01 X6:00 X7:00 X8:00 X9:00 X0:01</b> <b>X1:</b> Speed range lower limit value (default is 0X01) : The lower limit value is 1KM/H, which means that speeds less than 1km/h will not be detected and output); <b>X2:</b> Angle compensation (default is 0x00) : Angle compensation for the angle between the radar beam axis center and the movement of the moved target (car). If 0x0a is set, the compensation angle is 10 degrees; <b>X3:</b> Sensitivity (default is 0x05) : The setting range is 0x01~0x0f. The smaller the sensitivity value, the higher the sensitivity, which means the farther the detection distance (poor anti-interference). The larger the sensitivity value, the lower the sensitivity, which means the closer the detection distance (strong anti-interference); <b>X4:</b> Coming and going target detection (default is 0x00) : 0x00 means detection output for both coming and going targets; 0X01 means detection output for only coming targets; 0X02 means detection output for only going targets; <b>X5:</b> Number of measurable speed outputs per second (default is 0x01) : The larger the value, the lower the number of times the radar sensor can measure speed per second (0X00 means outputting about 22 frames per second). Each increment of 1 increases the time by 1 times. If set to 01, 11 frames per second will be output; <b>X6:</b> Speed unit (default is 0x00) : The unit of 0x00 is kilometers per hour, the unit of

	<p>0x01 is miles per hour; the unit of 0x02 is meters per second;</p> <p>X7:Vibration anti-interference coefficient range: 0x00~0x70 (default is 0X00) ;</p> <p>X8:Optocoupler pickup time: default value is 00;</p> <p>X9:Minimum speed value that triggers optocoupler pickup: default value is 00;</p> <p>X0:Protocol mode (default is 0X01) : 0X01 represents standard protocol mode, 0X02 represents customized protocol mode.</p>
--	---

6.4 : Command setting example:

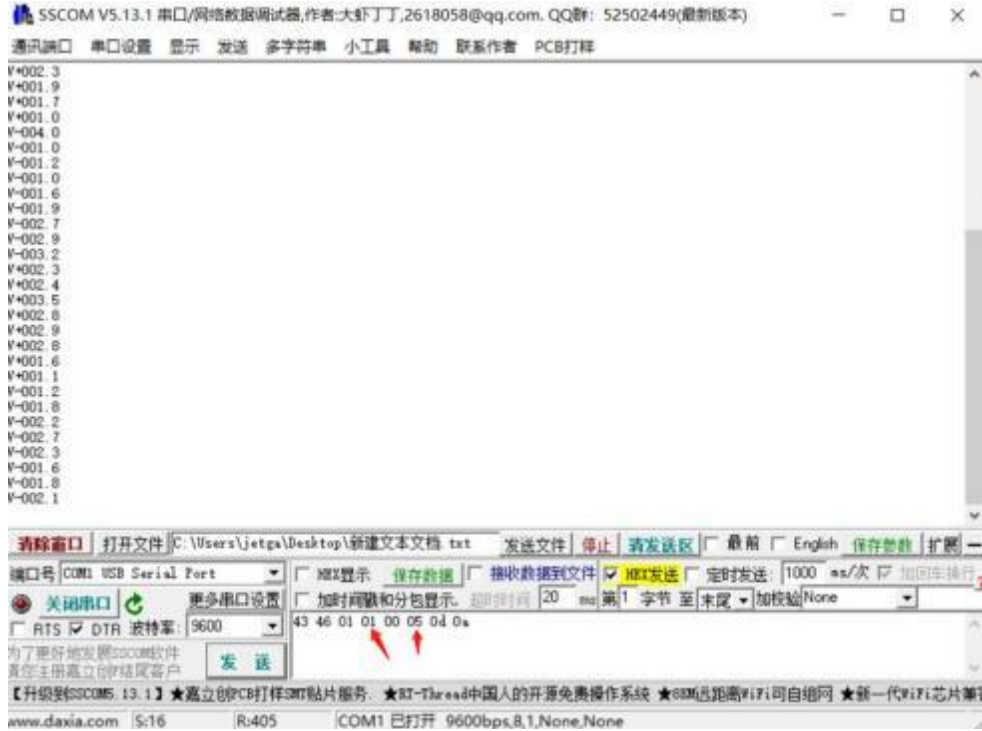

43 46 01 03 0a 05 0d 0a Command A Example: The minimum detection speed is 3km/h, the angle correction is 10°, and the sensitivity is 5.

43 46 02 01 02 00 0d 0a Command B example: Only incoming target detection is output, and the radar speed measurement data output is about 5.5 frames per second.

The above are sample parameters. Please set the parameters according to the site conditions during actual installation. For example, if it is set to the incoming speed and there is a speed trigger when going, you can set the radar sensitivity. The default is 0x05 and increase upward (the larger the value, the lower the sensitivity) until there is no abnormal speed value.

## 7. Radar dedicated host computer description

7.1 The radar needs to communicate with the computer through the RS485 USB switching tool. The positive and negative poles of the radar power supply need to be connected to a 12V DC power supply separately. After the radar is powered on, the red and green lights will flash three times continuously at the same time, indicating successful power on.



## 7.2 Host computer interface description







When using the host computer, please click here first. The red box content above will pop up. Please select the correct full port and baud rate of 9600, and then click "Open" to open the host computer.

ASCII speed data frame number accepting area  
 v+ indicates the detected arrival speed  
 v- indicates the detected direction velocity



After the host computer is correctly opened and the radar is successfully connected, you can start using the host computer to debug and set parameters.

## 8. Product specifications

### 8.1 Module size

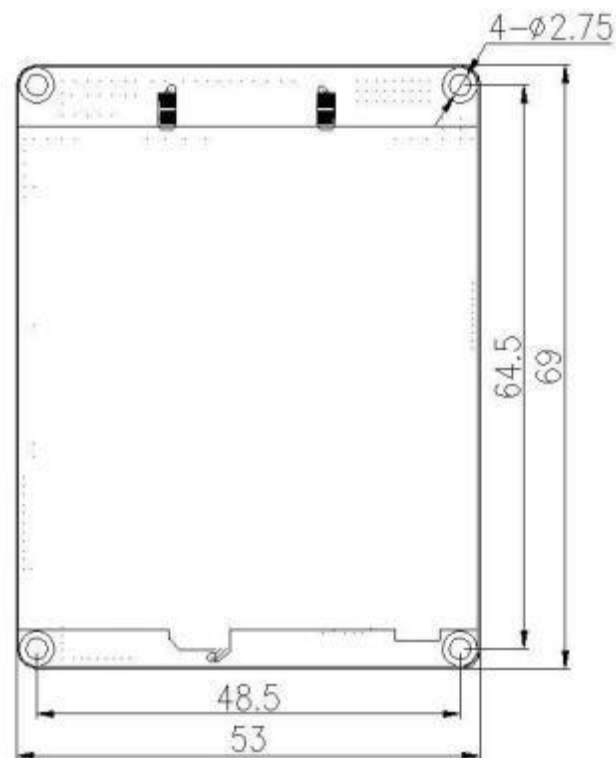

## 9. Installation Notes

### 9.1 Recommended application scenarios:

Install it on the left or right side of the road according to the direction of the road vehicles, as shown in the figure below, height: 1~2m; the recommended angle between the antenna emission surface and the road is less than  $10^\circ$ .

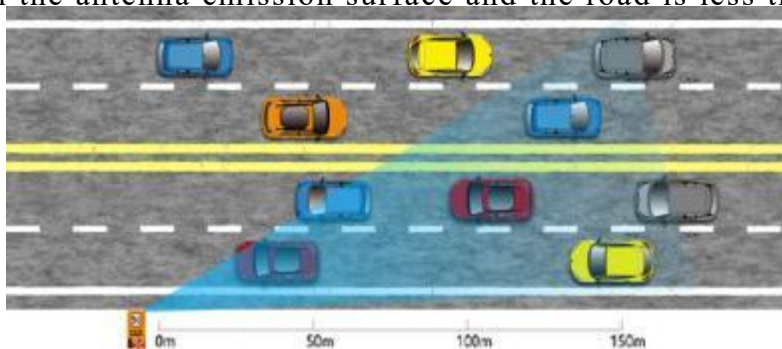

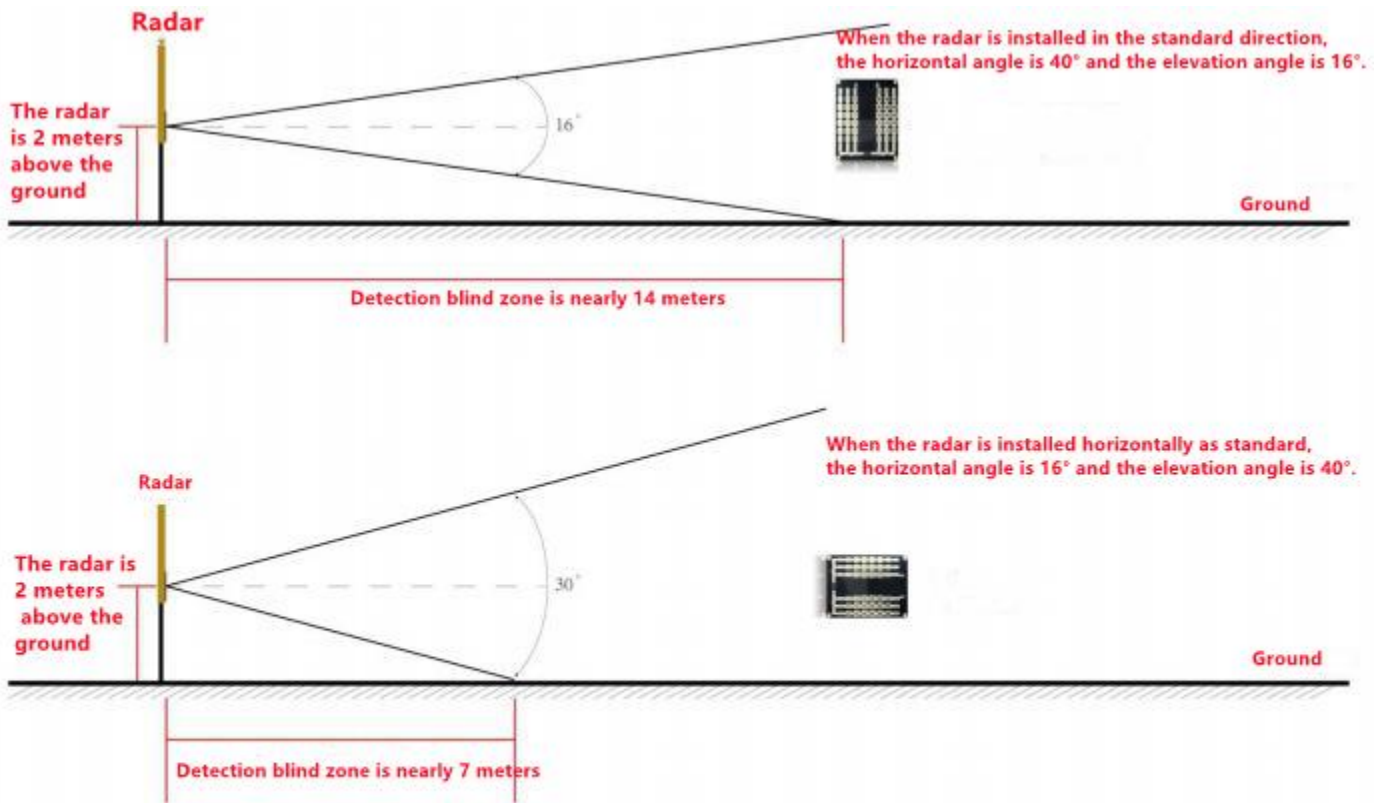

Radar installation diagram

## 9.2 Other notes:

- ◆ This radar only detects relatively moving targets within the inspected area, and does not detect completely stationary targets. The output result is information such as the speed of the nearest/fastest target in relative motion within the detection area.
- ◆ If there are obstructions such as water or metal in the radar emission direction that strongly reflect millimeter wave signals, the radar detection effect will be seriously affected.

## 10. Contact



### Shenzhen Hi-Link Electronic Co.,Ltd

Address: 1705, 17/F, Building E, XingheWORLD, Minle Community, Minzhi Street, Longhua District, Shenzhen

Tel: 0755-23152658/83575155

Email: sales@hlktech.com

Website: <https://www.hlktech.net/>

THANKS.